

# Low-cost Software- controlled Phase Shifting Network for Generating Spatiotemporally Variable Waveforms

Kobe Prior\*, Aidan Malensek,  
Matthew Dodd, Atef Elsherbeni

[kdprior@mines.edu](mailto:kdprior@mines.edu) [aidan\\_malensek@mines.edu](mailto:aidan_malensek@mines.edu) [mdodd@mines.edu](mailto:mdodd@mines.edu)

[aelsheerb@mines.edu](mailto:aelsheerb@mines.edu)



# Outline

## ■ Description of System Components

- Phase Shifting Network
- Software Defined Radio
- Microcontroller
- Antenna Arrays
- Mechanical Assembly

## ■ Characterizing System Performance

- Scattering Parameters

## ■ Graphical User Interface

- Phase Calibration
- Beam Steering Demonstration

## ■ Structured Waveforms

- Hermite Gaussian (HG)
- Laguerre Gaussian (LG)

## ■ Future Work

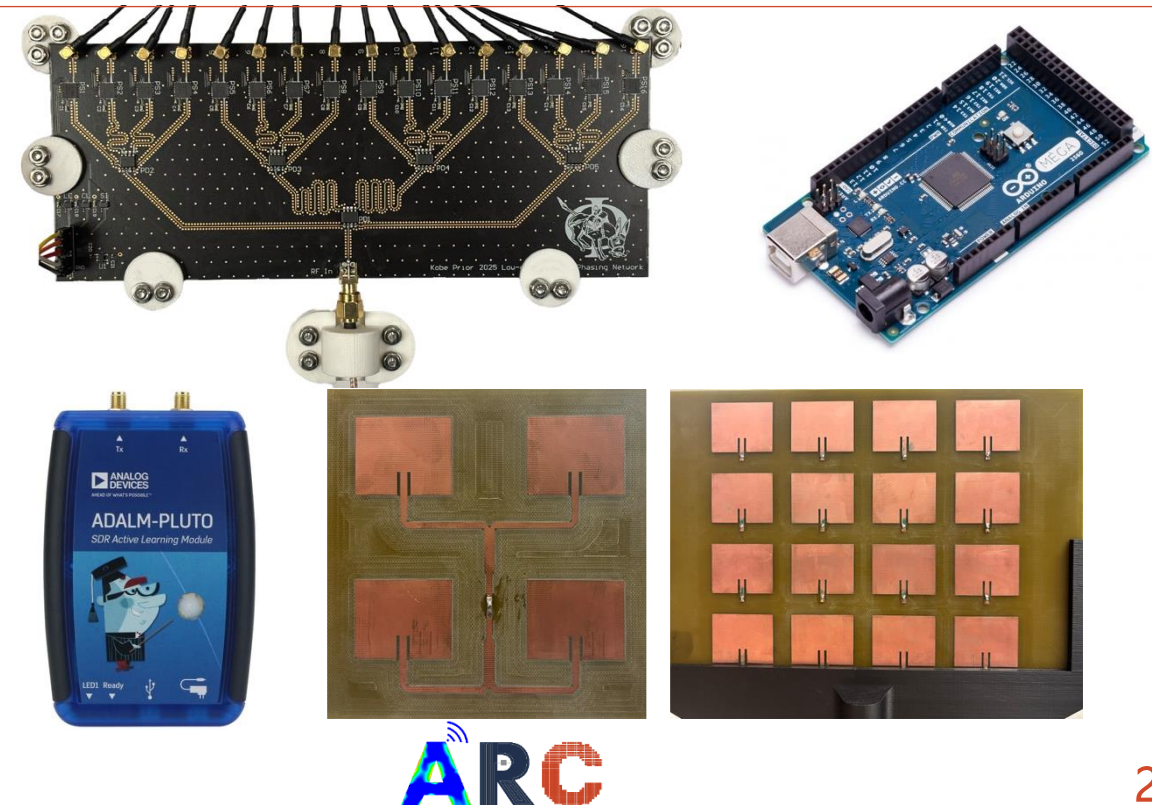

# System Components

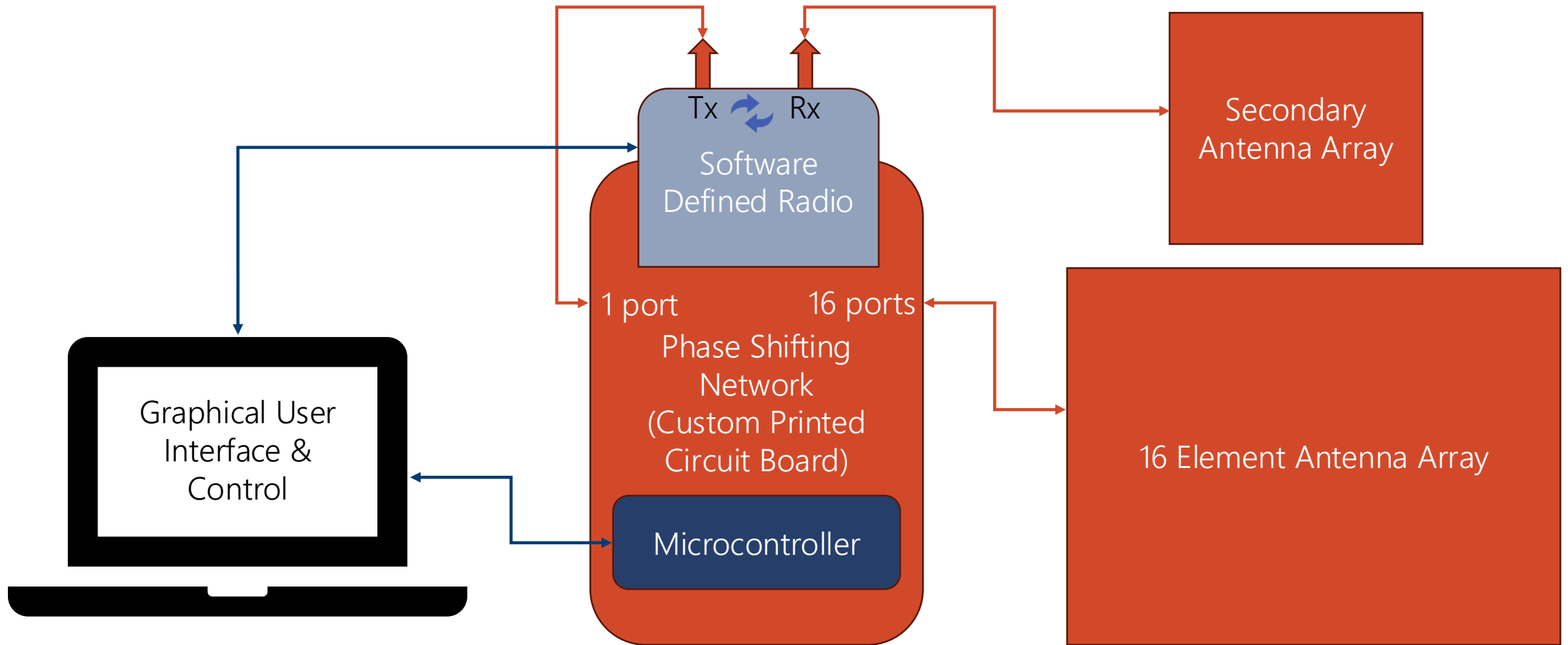

# Custom Built Phase Shifting Network

- 16 8-bit digital phase shifters (PE44820)

- Each phase shifter has a unique address
- Each is controlled using 3 Serial Lines
  - Serial In (SI): Loads the phase control word
  - Clock (CLK): Advances data into the device
  - Latch Enable (LE): Updates the phase output
- 102  $\mu$ s is required to adjust all 16 phase shifters

- Grounded Coplanar Waveguide Feed Line

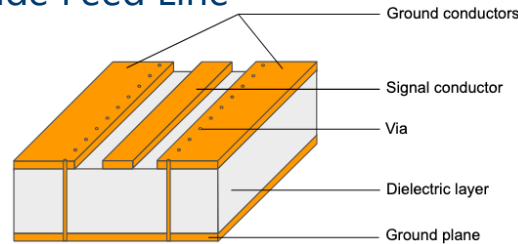

- 16 MMCX to SMA Cables

- These cables connects the phase shifters to the elements of the antenna array

- 16:1 (5 4:1) Wilkinson Power Divider(Tx)/Combiner(Rx)

- Logic Level Shifters

- Converts 5V logic level signals from MCU to 3.3V

- Voltage Regulator

- Uses MCU 5 V and provides 3.3 Vcc to all chips

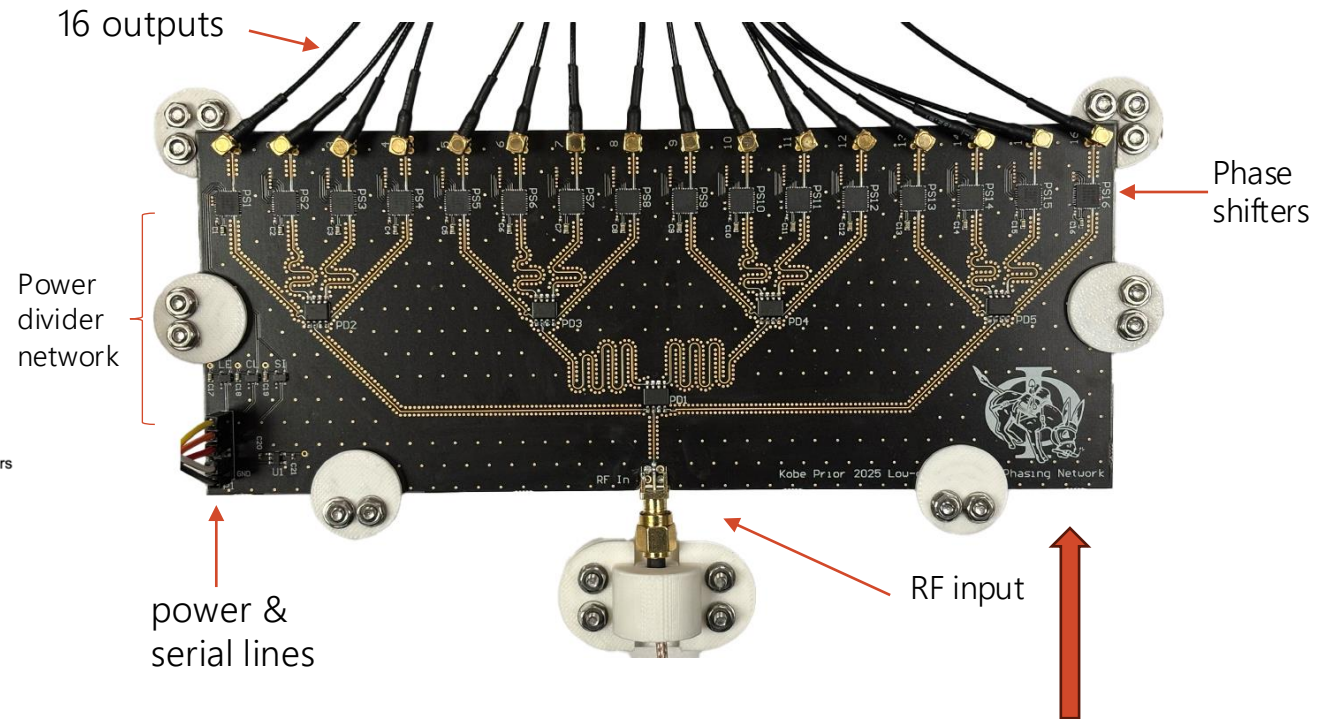

Top: 1oz copper pour  
Dielectric:  $\epsilon = 4.2$ , 0.12 mm  
GND: 0.5 oz copper pour  
Core:  $\epsilon = 4.2$ , 1.1644 mm  
VCC: 0.5 Oz copper pour  
Bottom: 1 oz copper pour

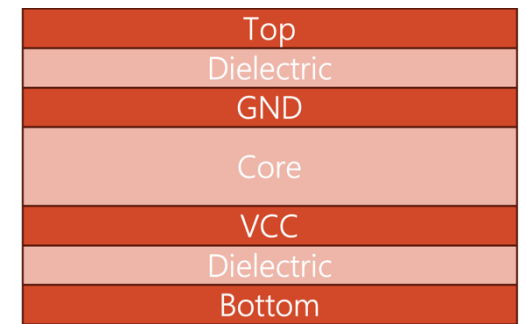

4-Layer Board

# Software Defined Radio

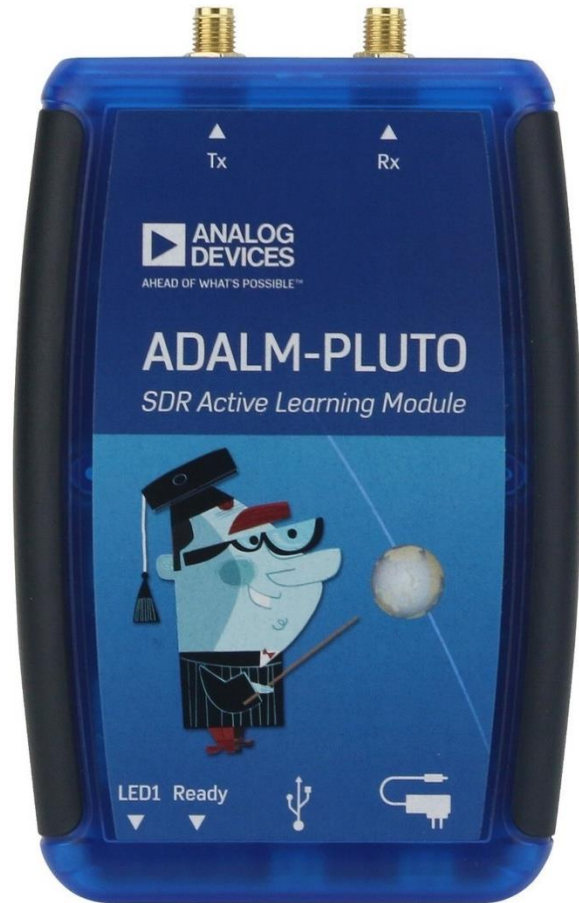

- Full duplex software defined radio (ADALM-PLUTO)
- A continuous wave is transmitted to provide a tone at a configurable frequency using a cyclic buffer
- Received power is computed as the mean of the squared magnitudes of complex baseband samples

$$P = \frac{1}{N_{\text{avg}}} \sum_{k=1}^{N_{\text{avg}}} \left( \frac{1}{M} \sum_{n=1}^M |r_k[n]|^2 \right)$$

- Received power plots are generated using the average of  $N_{\text{avg}} = 4$  received buffers.

# Arduino Mega Microcontroller

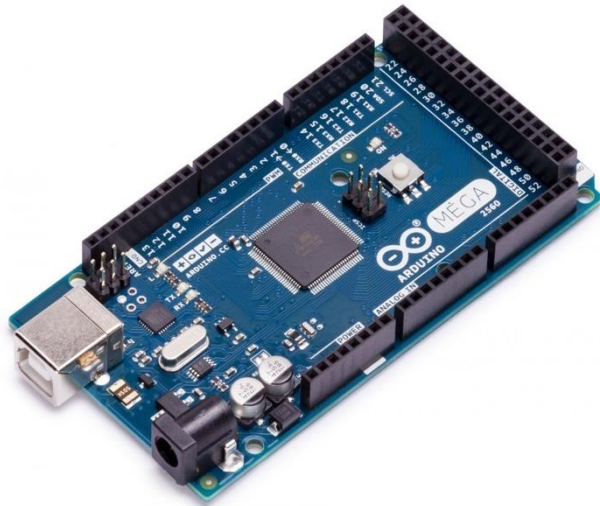

- Clock
- Latch Enable (Top)  
Serial In (Bottom)

## Hardware Serial Peripheral Interface (SPI)

- Clock rate = 8 MHz

## Serial Connection to Computer

- The computer sends phase words to the Arduino to preprocess and latch into the phase shifters

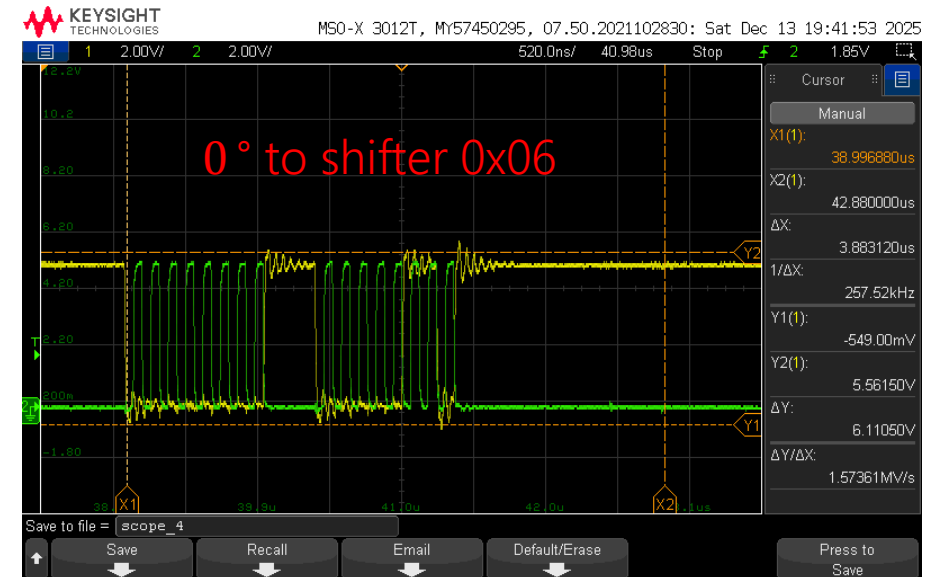
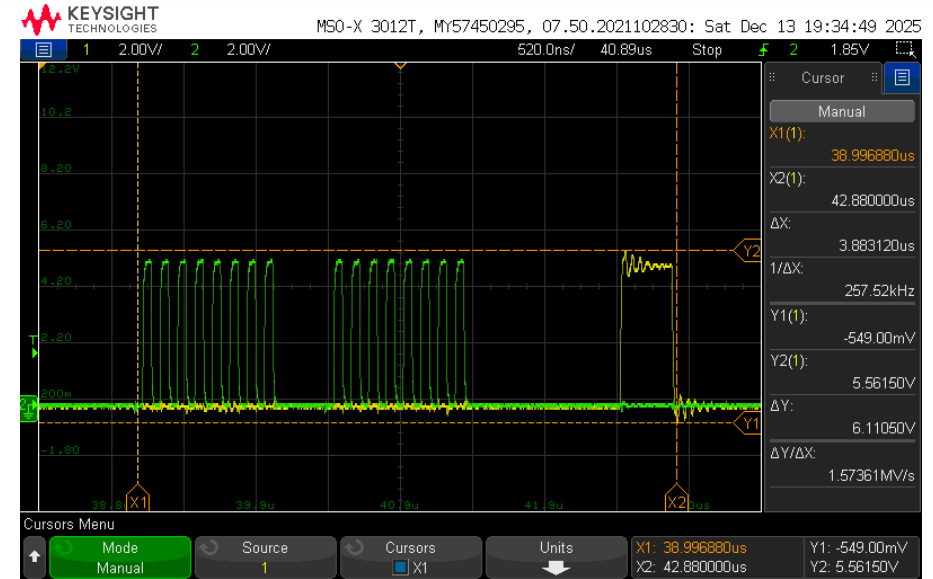

# Transmit and Receive Antenna Arrays

Secondary

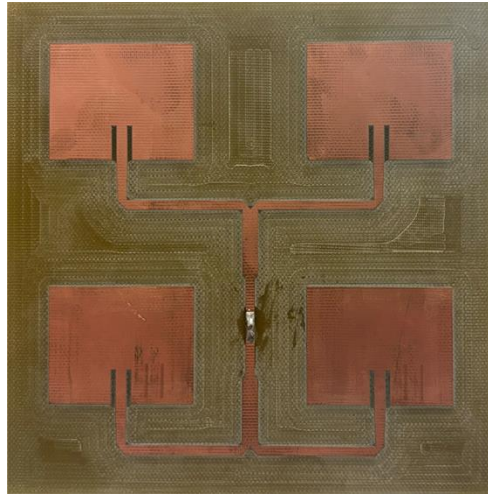

Primary

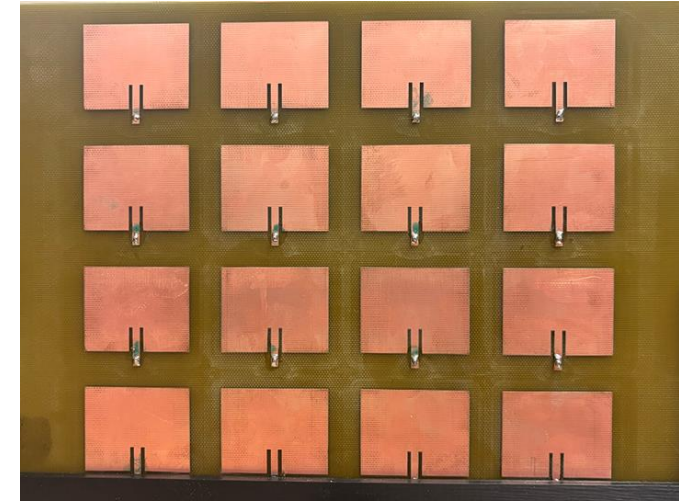

Simulation Results using CEMS

Measured Input Reflection Coefficient

S11 vs Frequency

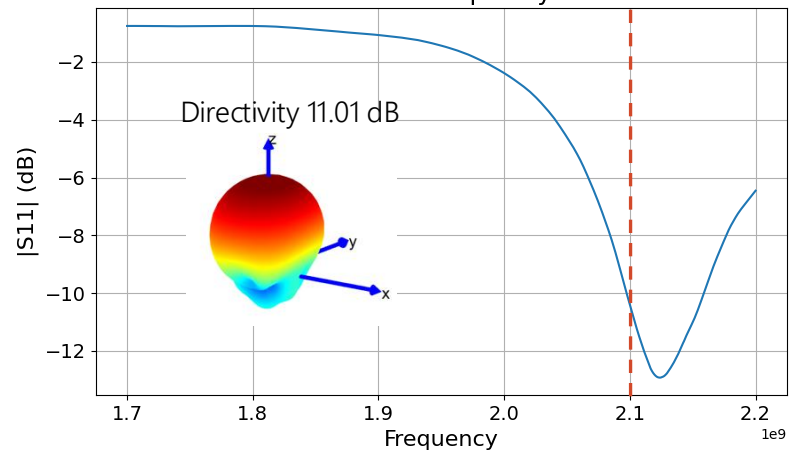

S11 for All 16 Elements

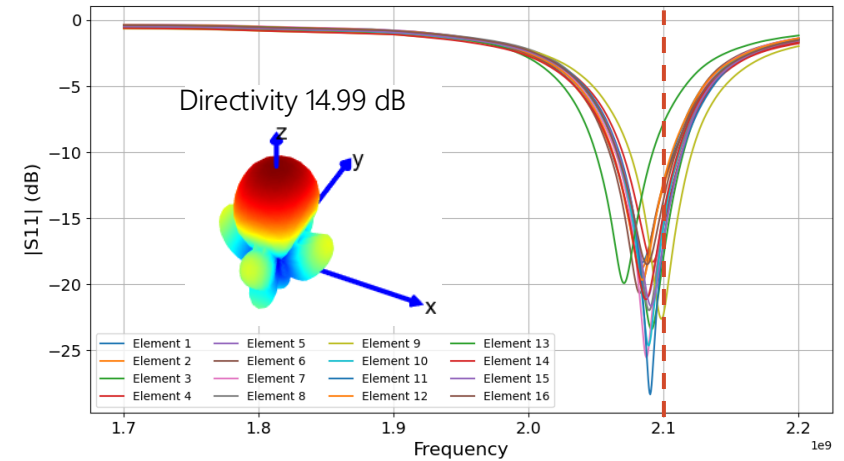

# Mechanical Assembly

16-element Antenna Array

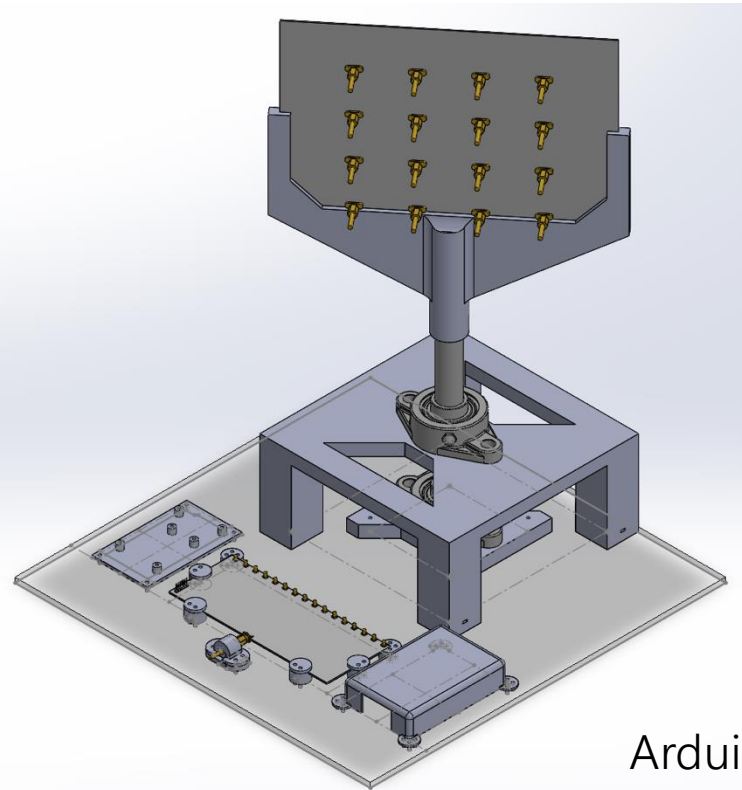

Arduino  
Mega

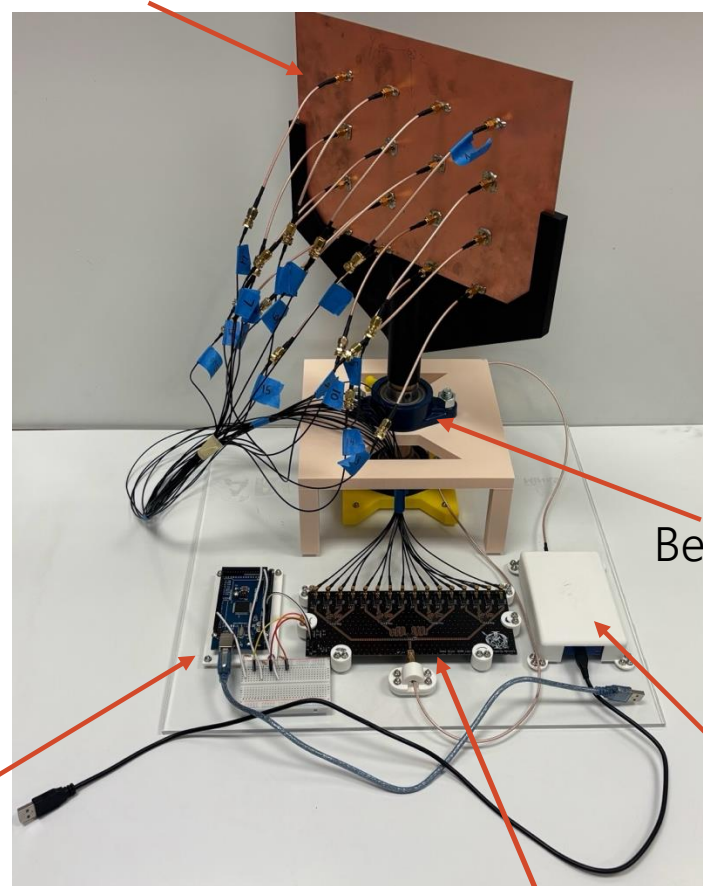

Bearings

Custom Phase Shifting Board

- The mechanical design for the system includes:

- 3D Printed Parts
  - Array stand upper and lower
  - PLUTO SDR mount
  - Arduino mount
  - Clips for phase shifter board
- Laser cut  $\frac{1}{4}$ " thick acrylic base plate
- Two bearings
- M3 bolts and nuts secure everything to the base plate

Software  
Defined  
Radio

# 16 Ports Scattering Parameters

S11 Magnitude (dB) for Each Port

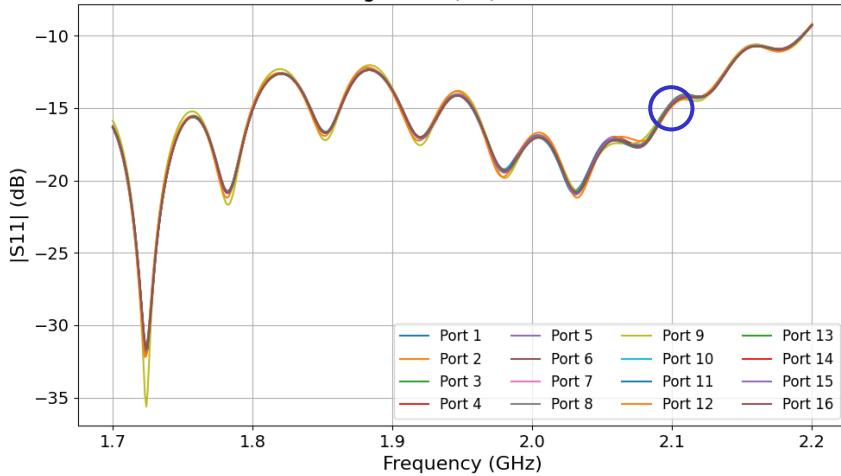

S21 Magnitude (dB) for Each Port

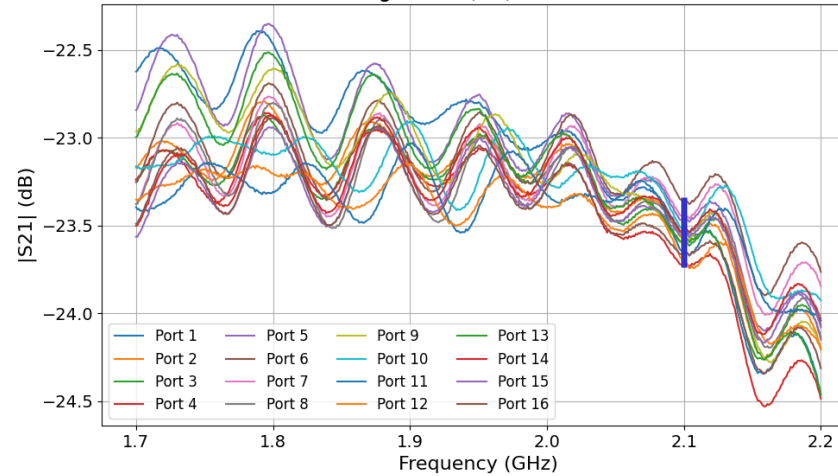

S22 Magnitude (dB) for Each Port

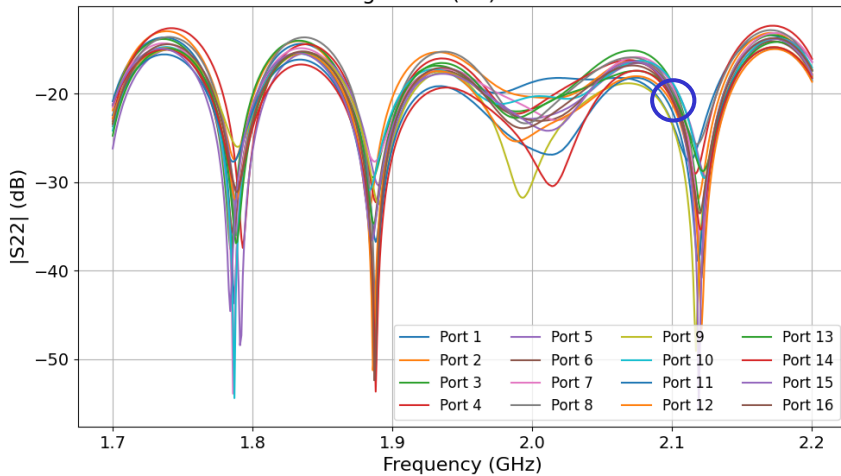

Relative S21 Phase (Referenced to Longest Path at FREQ)

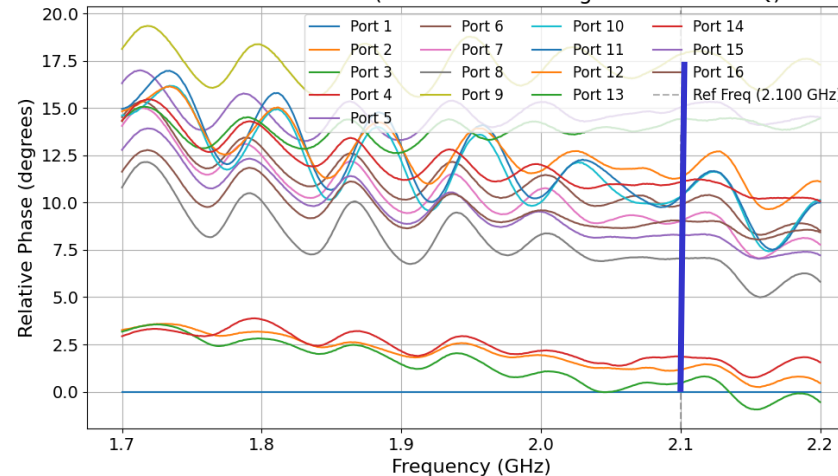

@2.1 GHz

- Insertion loss difference is maximum of 0.5 dB
- Maximum phase difference of 17.5 degrees (to be calibrated to have 0 phase difference with software)
- S11 and S22 at all ports are all at the same level

# Calibration Process

- Determine the largest phase offset
- Compute the difference in phase and store them into *phase\_offsets* variable
- Before sending phases to the microcontroller, adjust the phase offsets of each element to coincide with the largest phase offset.
- This is all automated in the graphical user interface, which generates the required calibration
- A short video is shown on the following slide demonstrating the calibration process within the graphical user interface

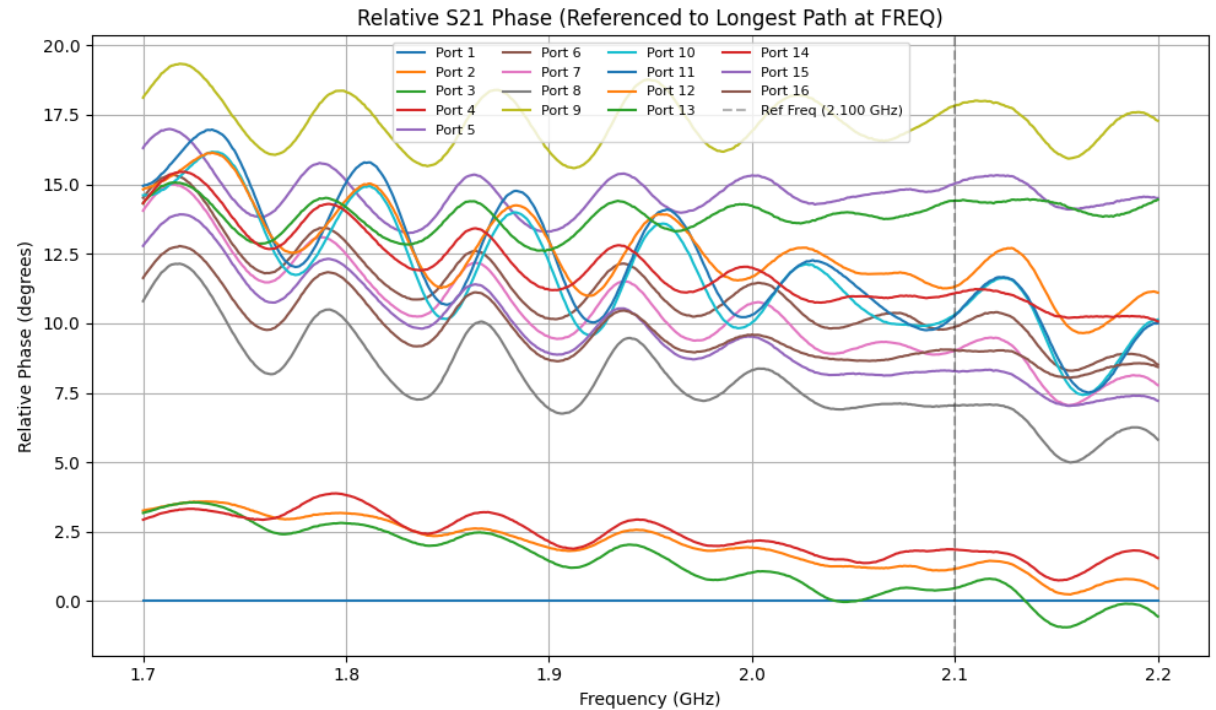

# Calibration Process using Graphical User Interface

SELECT ARDUINO PORT

## Antenna Array Control

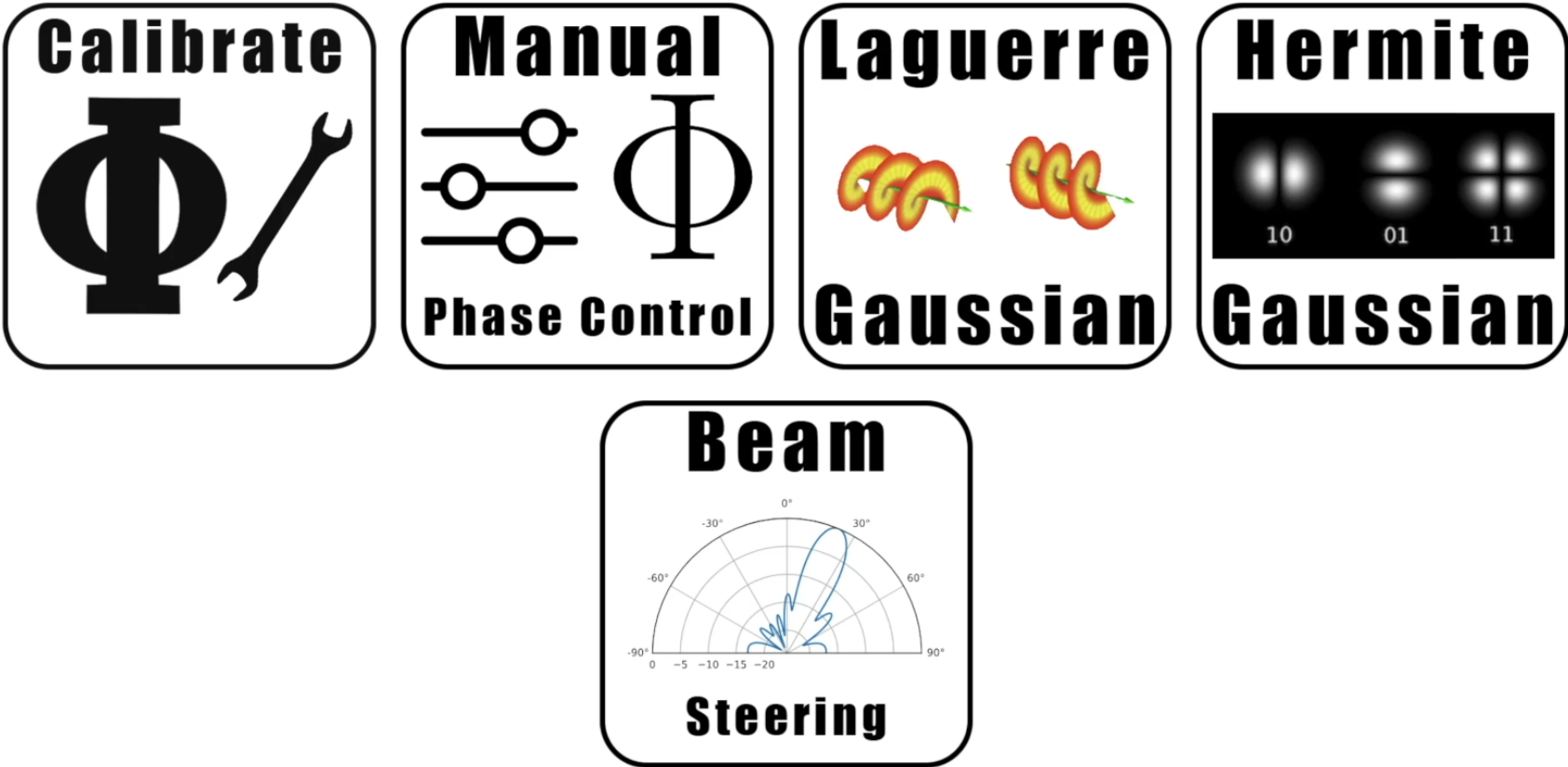

The GUI features five main control buttons and a steering plot:

- Calibrate**: Represented by a large Greek letter  $\Phi$  and a wrench icon.
- Manual Phase Control**: Represented by three sliders and a Greek letter  $\Phi$ .
- Laguerre Gaussian**: Represented by two 3D Laguerre Gaussian beam patterns.
- Hermite Gaussian**: Represented by a 2D intensity plot with three spots labeled 10, 01, and 11.
- Beam Steering**: A polar plot showing beam steering directions. The plot has an angular scale from 0° to 90° and a radial scale from 0 to -20. A blue arrow indicates the current steering direction.

# Beam Steering Graphical User Interface

- The Beam Steering page has two features

- Transmit Mode

- The user requests an angle to steer to  $(\theta_0, \phi_0)$
- Appropriate phases are computed to steer the main lobe in that direction using progressive phase shifts:

$$\beta_x = -kd_x \sin \theta_0 \cos \phi_0, \quad \beta_y = -kd_y \sin \theta_0 \sin \phi_0$$

- Then the receive antenna (2x2) will capture the strongest signal in  $(\theta_0, \phi_0)$  direction

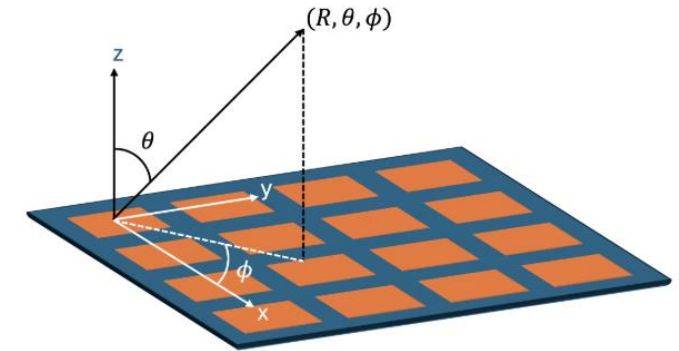
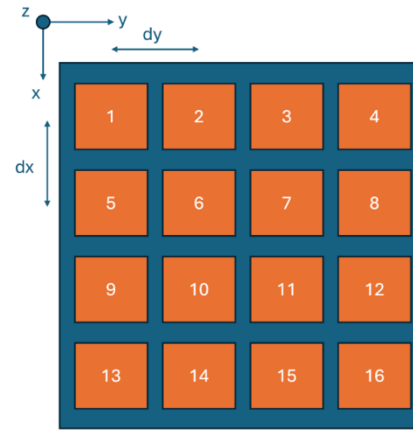

- Receive Mode operates in a similar way

- 256 different phase states are assigned sequentially to the 16-element array scanning a range of angles  $\theta \in [0, 45]$ ,  $\phi \in [0, 360)$  and average energy is sampled at each phase state.
- One of the states produces the largest energy related to the direction of the incident beam from the 2x2 array.
- An example is shown for an approximate received signal at  $\theta = 12.9^\circ$ ,  $\phi = 56.2^\circ$

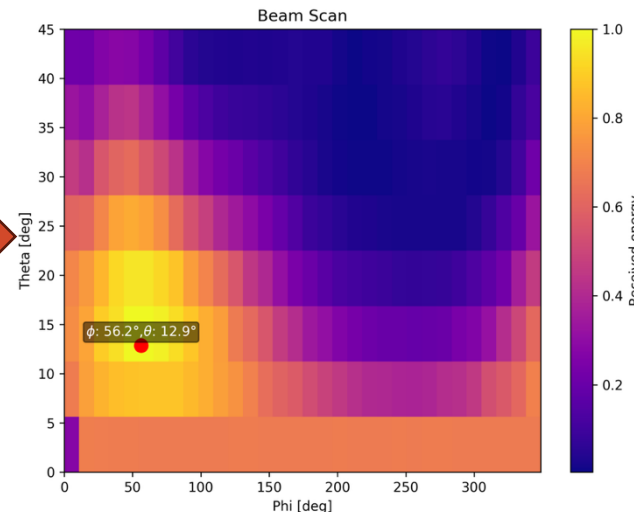

Example AoA Estimation  
 $\theta = 12.9^\circ$ ,  $\phi = 56.2^\circ$

# Beam Steering Transmit Mode Demonstration

Live Received Plot to Identify Main Lobe Direction

\*Sticky note is marked at 15 degrees

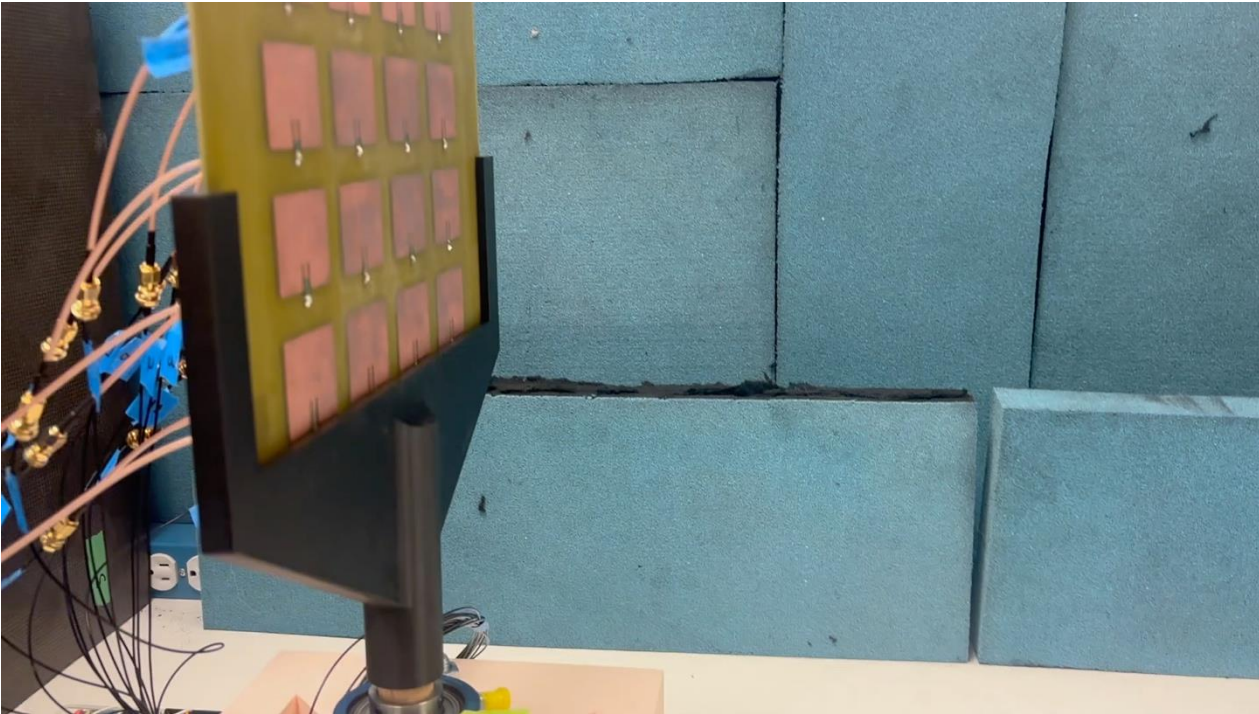

Array Factor Animation  $\theta \in [0^\circ, 60^\circ]$ ,  $\phi = 90^\circ$

Normalized Array Factor ( $\theta=0.0^\circ$ )

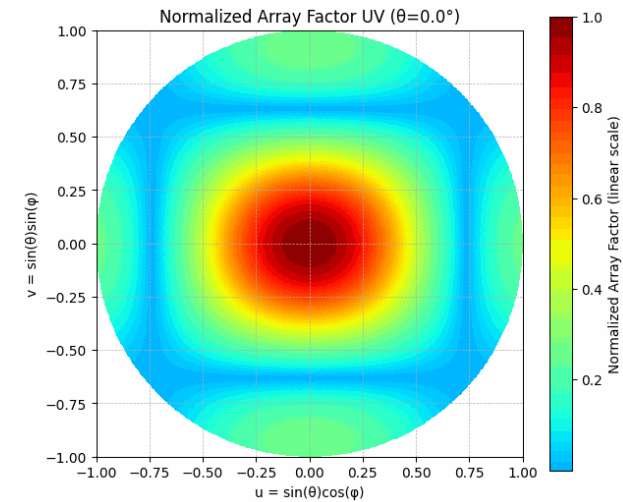
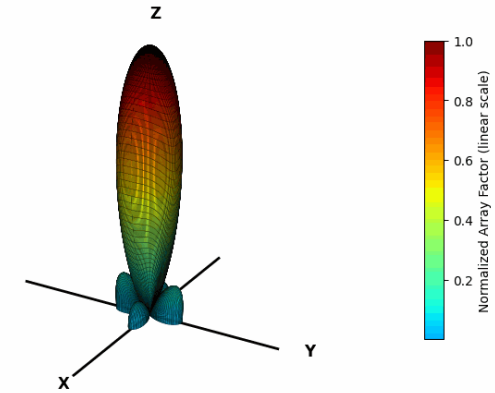

# Phase Assignment for Hermite Gaussian Modes

Several Hermite Gaussian Waveforms can be approximated with the following phase assignments. CEMS full wave simulation software is used to generate directivity plots

● 0 Degrees

■ 180 Degrees

$$\mathbf{E}_{HG}(x, y, z) = \frac{E_{x0}}{w(z)} H_m \left( \sqrt{2} \frac{x}{w(z)} \right) H_n \left( \sqrt{2} \frac{y}{w(z)} \right) e^{-\frac{r^2}{w_0^2(z) \left(1 + i \frac{z}{z_r}\right)}} e^{-i\psi_{m,n}} e^{-ikz} \hat{\mathbf{x}}$$

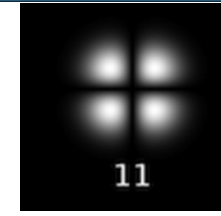
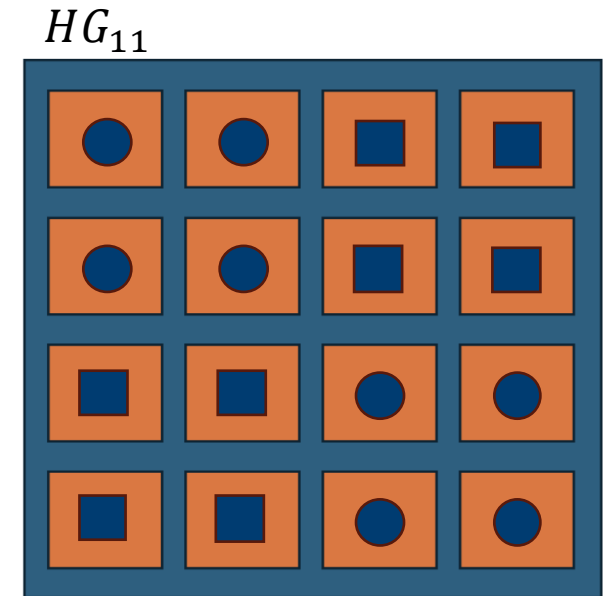
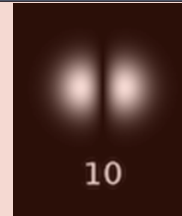
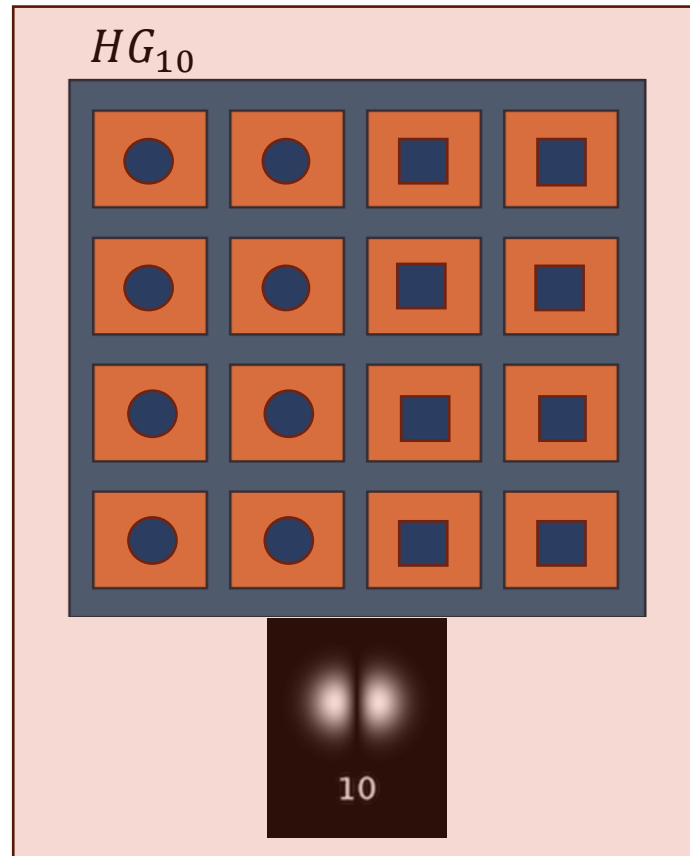
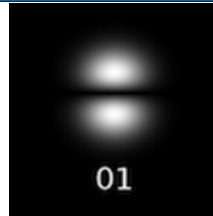
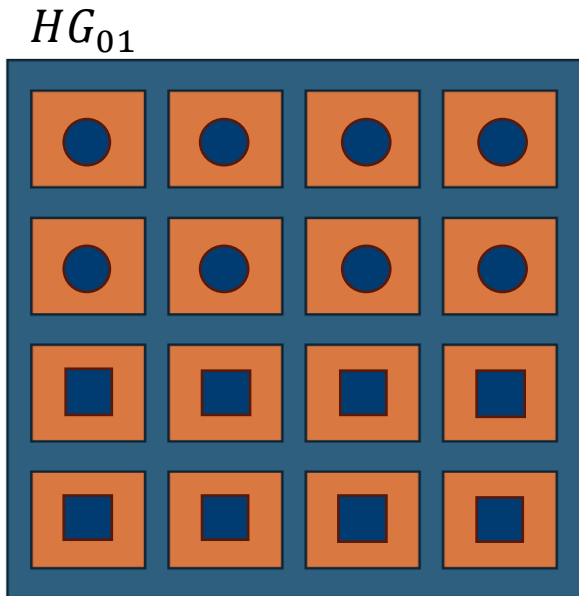

# Structured Waveforms: Hermite Gaussian Mode (1,0)

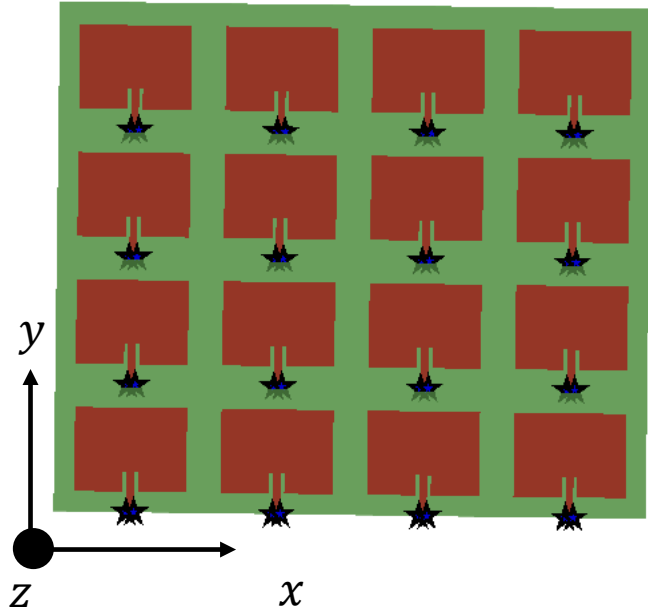
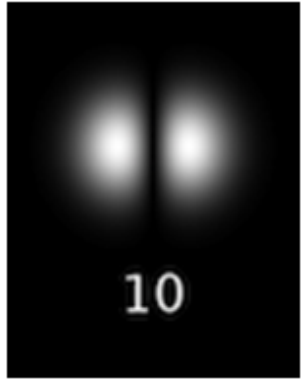

- 0 Degrees
- 180 Degrees

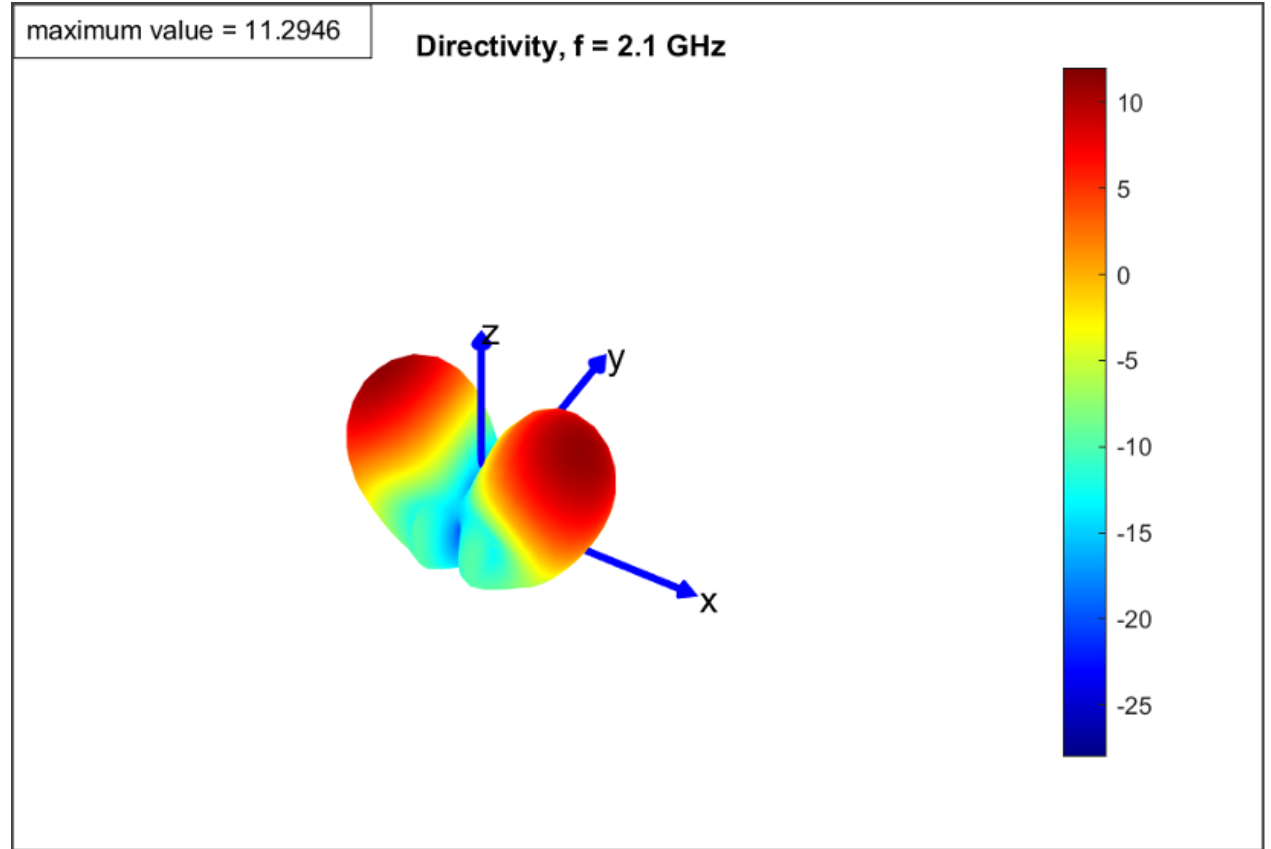
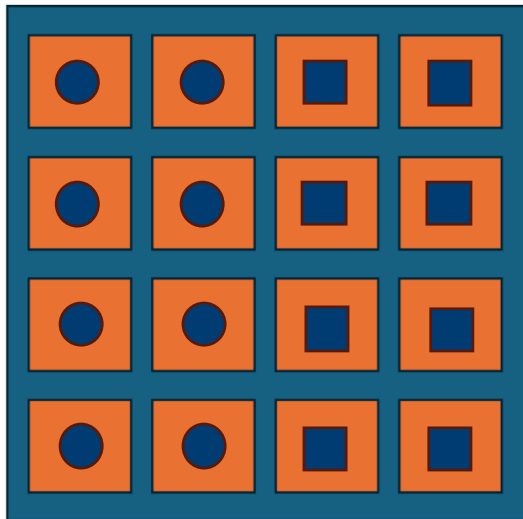

# Structured Waveforms: Hermite Gaussian Mode (1,0)

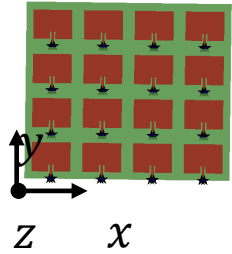
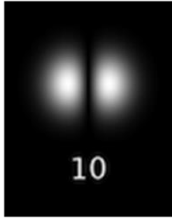

maximum value = -1.3593

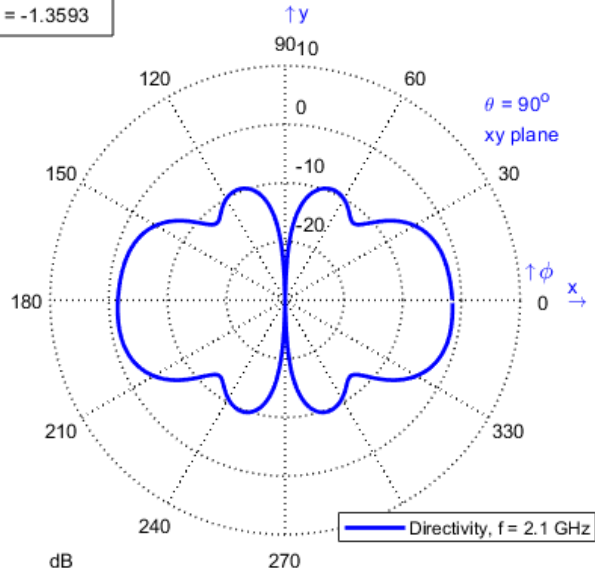

maximum value = 11.2988

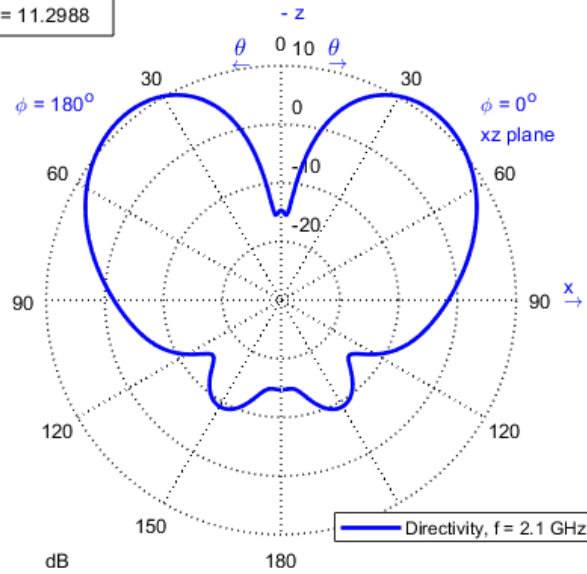

maximum value = -13.5146

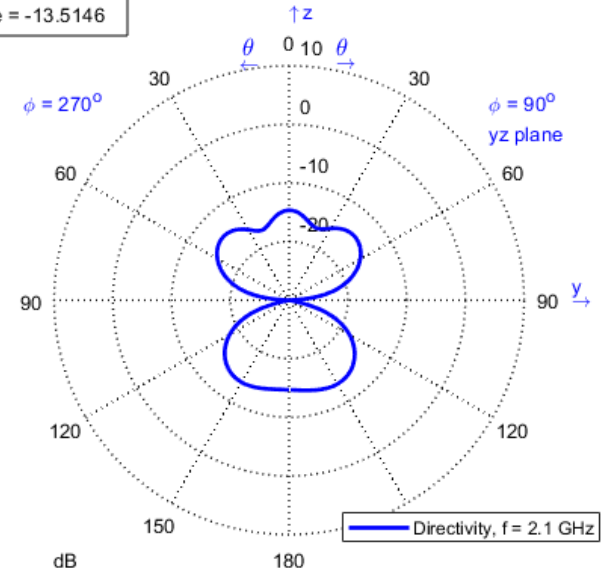

# Phase Assignment for Laguerre Gaussian Modes

$$\mathbf{E}_{LG}(r, \phi, z) = \frac{E_{x0}}{w(z)} \left( \frac{r\sqrt{2}}{w(z)} \right)^{|L|} e^{-\frac{r^2}{w^2(z)}} L_p^{|L|} \left\{ \frac{2r^2}{w^2(z)} \right\} e^{\frac{jkr^2}{2R(z)}} e^{j|L|\phi} e^{j[2p+|L|+1]\psi(z)} e^{-jkz} \hat{\mathbf{x}}$$

To approximate modes  $p=0$ ,  $L=-2, -1$ , and  $2$  multiply the phase column by the mode number  $L$

$$\phi = \arctan(d_y/d_x)$$

$d_y$  = vertical distance from center

$d_x$  = horizontal distance from center

Mode  $p=0$   $L=1$

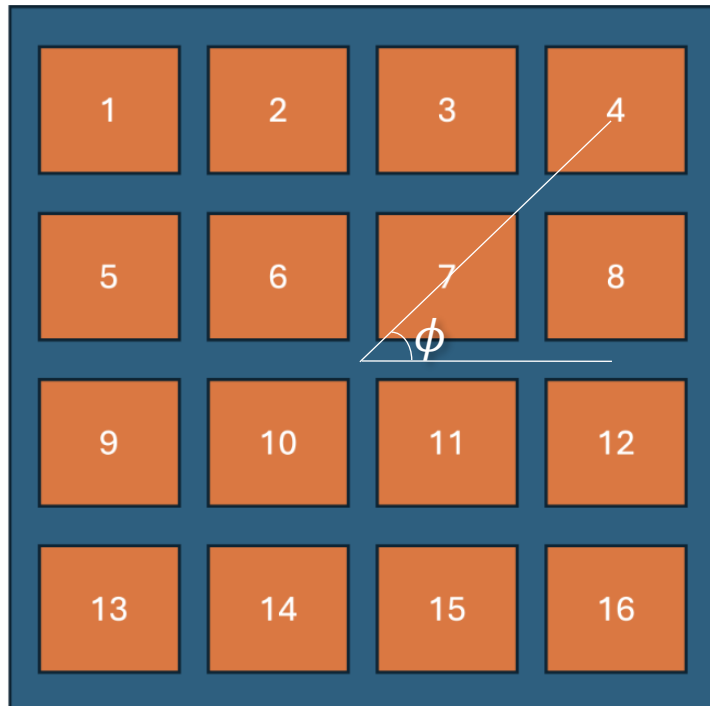

Element	Phase (deg)	Element	Phase (deg)
1	140.2	9	195.5
2	111.8	10	219.8
3	68.2	11	320.2
4	39.8	12	344.5
5	164.5	13	219.8
6	140.2	14	248.2
7	39.8	15	291.8
8	15.5	16	320.2

# Laguerre Gaussian Mode $p=0, L=1$

For LG mode 1, the near-field electric field phase is plotted using Feko to confirm helicity.

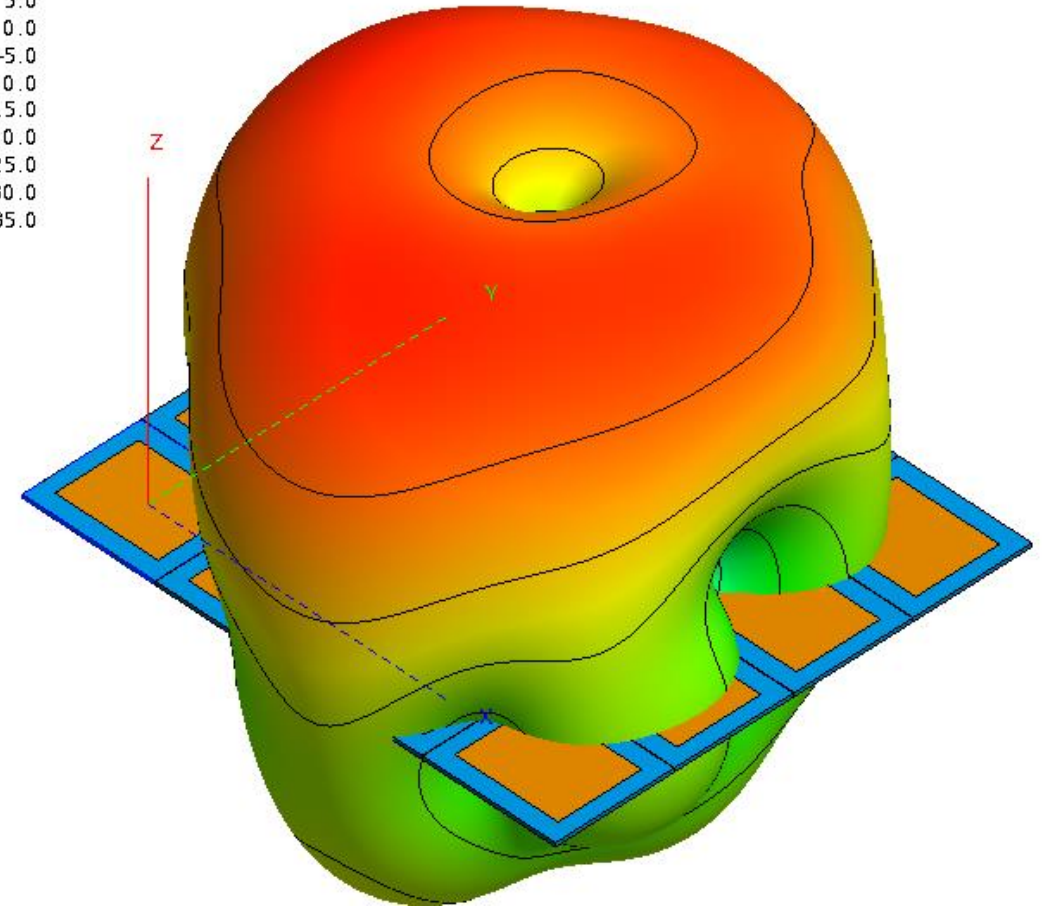
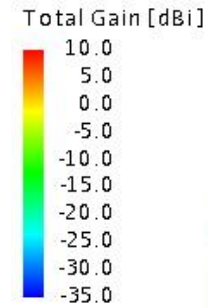
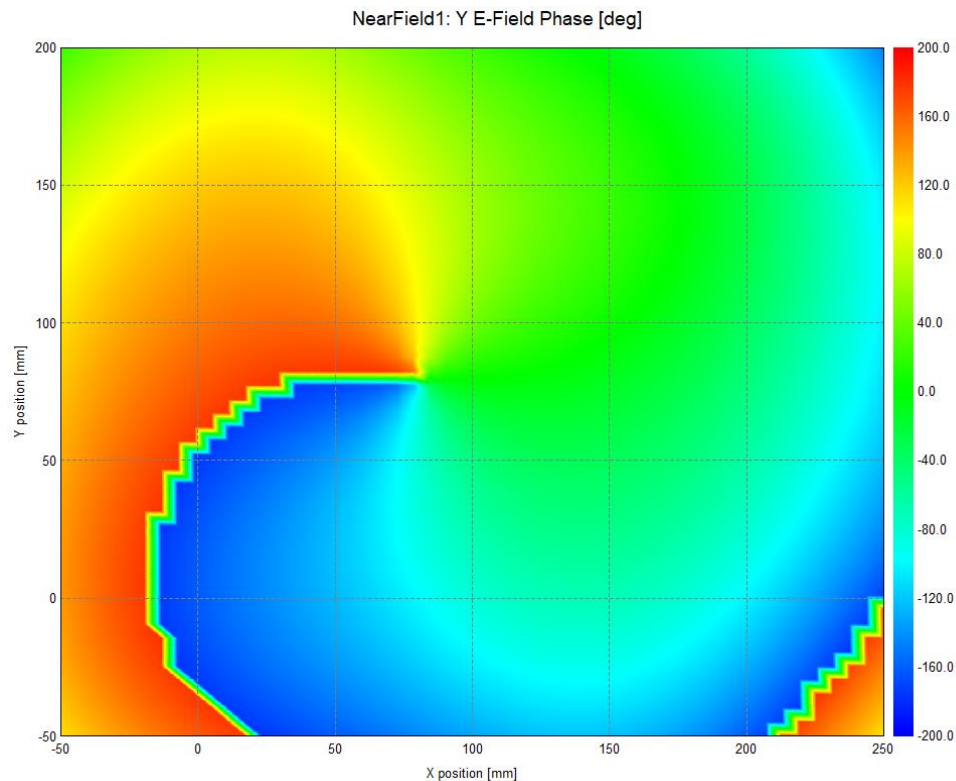

# Plane Cuts for Laguerre Gaussian Mode $p=0, L=1$

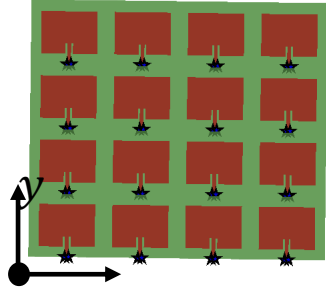

maximum value = -1.0819

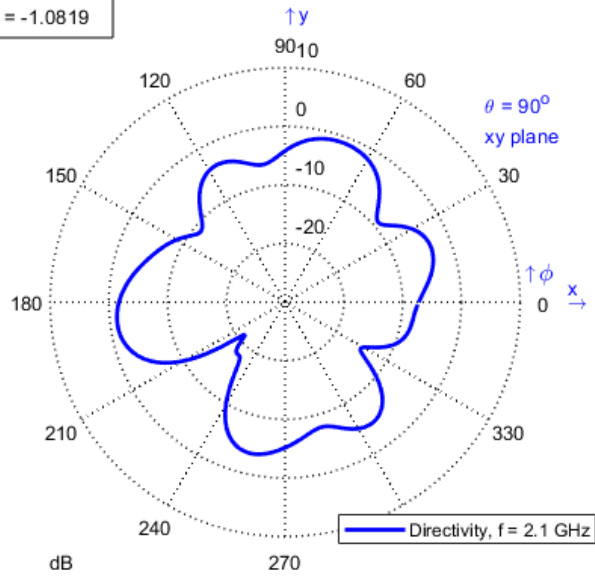

maximum value = 8.3212

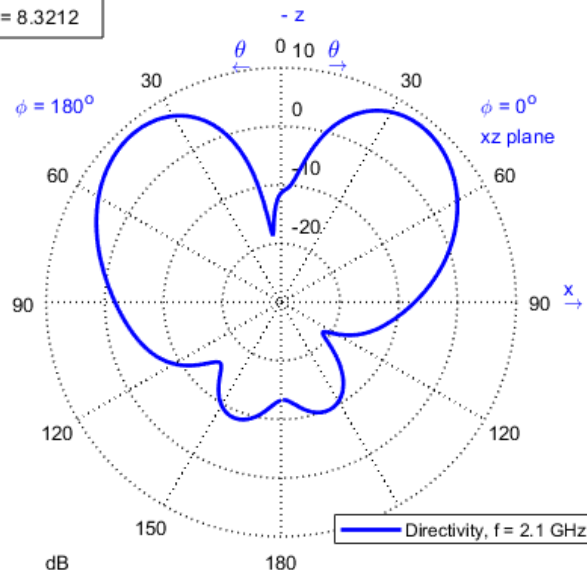

maximum value = 7.4118

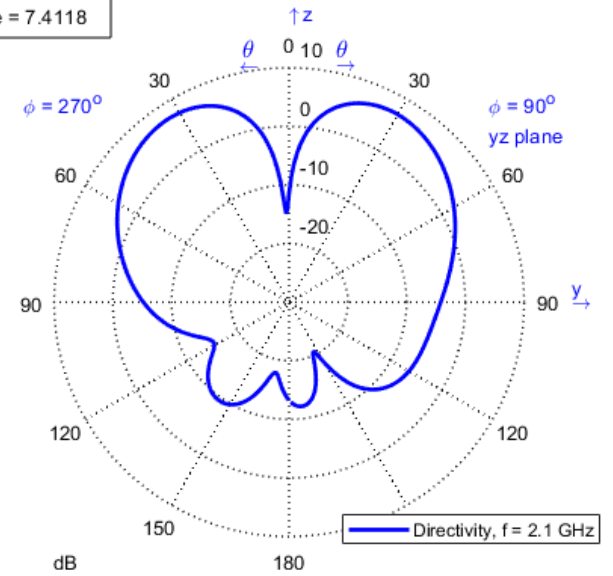

# Future Work

- Design and fabrication of sixteen-element concentric uniform circular array for pure multimodal excitation.
- Measure scattered field from different targets of different materials and shapes.
- Prepare a classroom demonstration to introduce students to the concept of phased array applications.

# Acknowledgements

This project received support from:

VICEROY (Griffis Institute, Air Force Laboratory)

Defense Advanced Research  
Projects Agency (DARPA) EMON  
Project





# Antenna Array Control

**Calibrate**



Calibrate icon showing a large Greek letter  $\Phi$  and a wrench.

**Manual**

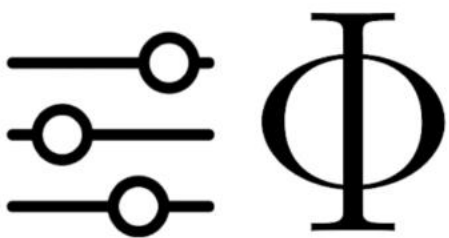

**Phase Control**

Manual icon showing three sliders and a large Greek letter  $\Phi$ . Below the icon is the text "Phase Control".

**Laguerre**



**Gaussian**

Laguerre icon showing two 3D Gaussian beam patterns. Below the icon is the text "Gaussian".

**Hermite**



**Gaussian**

Hermite icon showing a 2D intensity plot with three spots labeled 10, 01, and 11. Below the icon is the text "Gaussian".

**Beam**

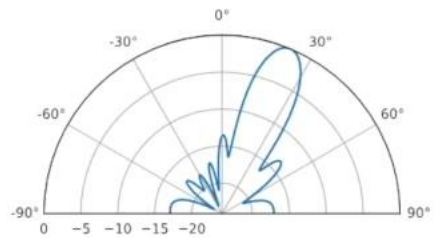

**Steering**

Beam icon showing a polar plot with angles from 0° to -90° and a beam steering curve. Below the plot is the text "Steering".

